

## CARATTERISTICHE TECNICHE | DATA SHEET DONNÉES TECHNIQUES | TECHNISCHE DATEN

### SUPREMA SALUMERIA 315-350-370

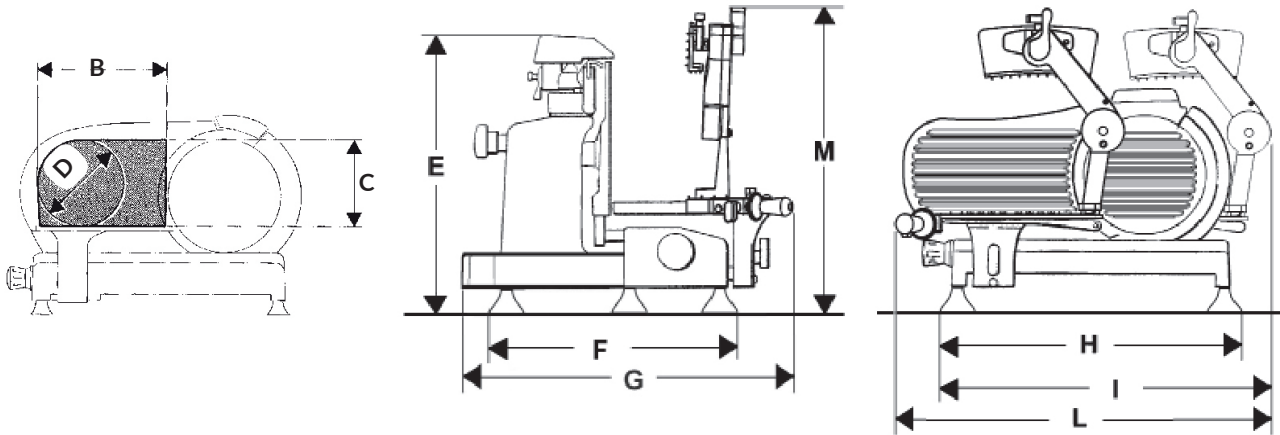

SPECIFICHE   SPECIFICATIONS SPÉCIFICATIONS   TECHNISCHE MERKMALE			
	PES315	PES350	PES370
∅ Lama   ∅ Blade ∅ Lame   ∅ Messer	315 mm	350 mm	370 mm
Spessore taglio Cut thickness Épaisseur de coupe Schnittbreite	0 - 14 mm	0 - 14 mm	0 - 14 mm
Capacità di taglio rettangolare Capacity (rectangle) Capacité (rectangle) Leistung (Rechteck)	280x225 mm	310x270 mm	340x280 mm
Capacità di taglio circolare Capacity (circle) Capacité (cercle) Leistung (Kreis)	225 mm	270 mm	280 mm
Peso netto   Net weight Poids net   Nettogewicht	41 kg	45 kg	56 kg
Potenza motore Motor rating Puissance moteur Motorleistung	0,25-0,30kW	0,30-0,35kW	0,30-0,35kW
Specifiche elettriche Electrical specifications Caractéristiques électriques Elektrische Eigenschaften		230V 50Hz 1PH 400V 50Hz 3PH	
Disponibile anche con Available also with Aussi disponible avec Verfügbar auch mit		120V 60Hz 1PH 220V 60Hz 1 PH	

DIMENSIONI DIMENSIONS   MASSE		
PES315	PES350	PES370
<b>B</b> 280 mm	<b>B</b> 310 mm	<b>B</b> 340 mm
<b>C</b> 225 mm	<b>C</b> 270 mm	<b>C</b> 280 mm
<b>D</b> 225 mm	<b>D</b> 270 mm	<b>D</b> 280 mm
<b>E</b> 510 mm	<b>E</b> 550 mm	<b>E</b> 560 mm
<b>F</b> 465 mm	<b>F</b> 490 mm	<b>F</b> 560 mm
<b>G</b> 640 mm	<b>G</b> 670 mm	<b>G</b> 740 mm
<b>H</b> 570 mm	<b>H</b> 600 mm	<b>H</b> 700 mm
<b>I</b> 660 mm	<b>I</b> 710 mm	<b>I</b> 840 mm
<b>L</b> 840 mm	<b>L</b> 890 mm	<b>L</b> 1030 mm
<b>M</b> 670 mm	<b>M</b> 665 mm	<b>M</b> 710 mm

Nota: A seguito della continua ricerca per migliorare sempre i nostri prodotti, le specifiche tecniche sono soggette a possibili variazioni  
 Note: As we actually strive to improve our products, specifications are necessarily subject to change without notice  
 Remarque: En raison de la recherche continue pour améliorer nos produits, les spécifications techniques sont sujettes à des possible variations  
 Anmerkung: Aufgrund der ständigen Forschung für die Verbesserung unserer Produkte, die Produktionsvorgabe können Änderungen zeigen